



# Rack-Mount Fail-Safe Transfer Switch

## Installation and Operations Manual

- C-8HFx
- C-16HFx



#### Instructions

This symbol is intended to alert the user to the presence of important operating and maintenance (servicing) instructions in the literature accompanying the appliance.



#### Dangerous Voltage

This symbol is intended to alert the user to the presence of un-insulated dangerous voltage within the product's enclosure that may be of sufficient magnitude to constitute a risk of electric shock to persons.



#### Protective Grounding Terminal

This symbol indicates a terminal that must be connected to earth ground prior to making any other connections to the equipment.

### Life-Support Policy

As a general policy, Server Technology does not recommend the use of any of its products in the following situations:

- life-support applications where failure or malfunction of the Server Technology product can be reasonably expected to cause failure of the life-support device or to significantly affect its safety or effectiveness.
- direct patient care.

Server Technology will not knowingly sell its products for use in such applications unless it receives in writing assurances satisfactory to Server Technology that:

- the risks of injury or damage have been minimized,
- the customer assumes all such risks, and
- the liability of Server Technology is adequately protected under the circumstances.

The term life-support device includes but is not limited to neonatal oxygen analyzers, nerve stimulators (whether used for anesthesia, pain relief or other purposes), auto-transfusion devices, blood pumps, defibrillators, arrhythmia detectors and alarms, pacemakers, hemodialysis systems, peritoneal dialysis systems, neonatal ventilator incubators, ventilators (for adults or infants), anesthesia ventilators, infusion pumps, and any other devices designated as "critical" by the U.S. FDA.

### Notices

301-0128-1 Rev. D (011711)

Copyright © 2006-2011 Server Technology, Inc. All rights reserved.

1040 Sandhill Drive

Reno, Nevada 89521 USA

#### All Rights Reserved

This publication is protected by copyright and all rights are reserved. No part of it may be reproduced or transmitted by any means or in any form, without prior consent in writing from Server Technology.

The information in this document has been carefully checked and is believed to be accurate. However, changes are made periodically. These changes are incorporated in newer publication editions. Server Technology may improve and/or change products described in this publication at any time. Due to continuing system improvements, Server Technology is not responsible for inaccurate information which may appear in this manual. For the latest product updates, consult the Server Technology web site at [www.servertech.com](http://www.servertech.com). In no event will Server Technology be liable for direct, indirect, special, exemplary, incidental or consequential damages resulting from any defect or omission in this document, even if advised of the possibility of such damages.

In the interest of continued product development, Server Technology reserves the right to make improvements in this document and the products it describes at any time, without notices or obligation.

Other trademarks and trade names may be used in this document to refer to either the entities claiming the marks and names or their products. Server Technology, Inc. disclaims any proprietary interest in trademarks and trade names other than its own.

The Globe logo is a trademark of Server Technology, Inc., registered in the US. Use of the logo for commercial purposes without the prior written consent of Server Technology may constitute trademark infringement and unfair competition in violation of federal and state laws.

Server Technology and the Globe logo are trademarks of Server Technology, Inc., registered in the US.

Sentry, Cabinet Distribution Unit, Rack-Mount Fail-Safe Transfer Switch, and **SMARTER** Technical Support are trademarks of Server Technology, Inc.



#### Please Recycle

Shipping materials are recyclable. Please save them for later use, or dispose of them appropriately.

# Table of Contents

<b>CHAPTER 1: INTRODUCTION</b>	<b>4</b>
Quick Start Guide.....	4
Technical Support .....	4
Equipment Overview.....	5
<b>CHAPTER 2: INSTALLATION</b>	<b>6</b>
Standard Accessories.....	6
Additional Required Items .....	6
Safety Precautions .....	6
Installing the Power Input Retention Bracket.....	7
Mounting .....	7
Optimizing the Transfer Thresholds.....	7
Connecting to the Power Source .....	7
Connecting Devices.....	7
<b>CHAPTER 3: OPERATIONS</b>	<b>8</b>
Modes of Operation.....	8
<b>CHAPTER 4: APPENDICES</b>	<b>9</b>
Appendix A: Technical Specifications .....	9
Appendix B: Warranty, Product Registration and Support .....	11

# Chapter 1: Introduction

## Quick Start Guide

The following instructions will help you quickly install and configure your Rack-Mount Fail-Safe Transfer Switch for use on your network. For detailed information on each step, go to the page number listed to the right.

1. Mount the Rack-Mount Fail-Safe Transfer Switch .....7
2. Optimize the transfer thresholds.....7
3. Connect to the power sources.....7
4. Connect the devices to the Fail-Safe Transfer Switch.....7

## Technical Support



Experience Server Technology's **FREE SMARTER Technical Support** - [Learn more...](#)

Server Technology understands that there are often questions when installing and/or using a new product. Free Technical Support is provided from 6:00 AM to 7:00 PM, Monday-Friday, Pacific Time.

Server Technology, Inc.

1040 Sandhill Drive

Reno, Nevada 89521 USA

Tel: 775.284.2000

Fax: 775.284.2065

Web: [www.servertech.com](http://www.servertech.com)

Email: [support@servertech.com](mailto:support@servertech.com)

## Equipment Overview

1. The Voltage Selector switch configures the Rack-Mount Fail-Safe Transfer Switch for the installed operational voltage.  
**NOTE:** This configures the brownout/over-voltage switching points.
2. The power inlets connect the Rack-Mount Fail-Safe Transfer Switch to the electrical power sources.
3. LEDs display the input feeds power status.

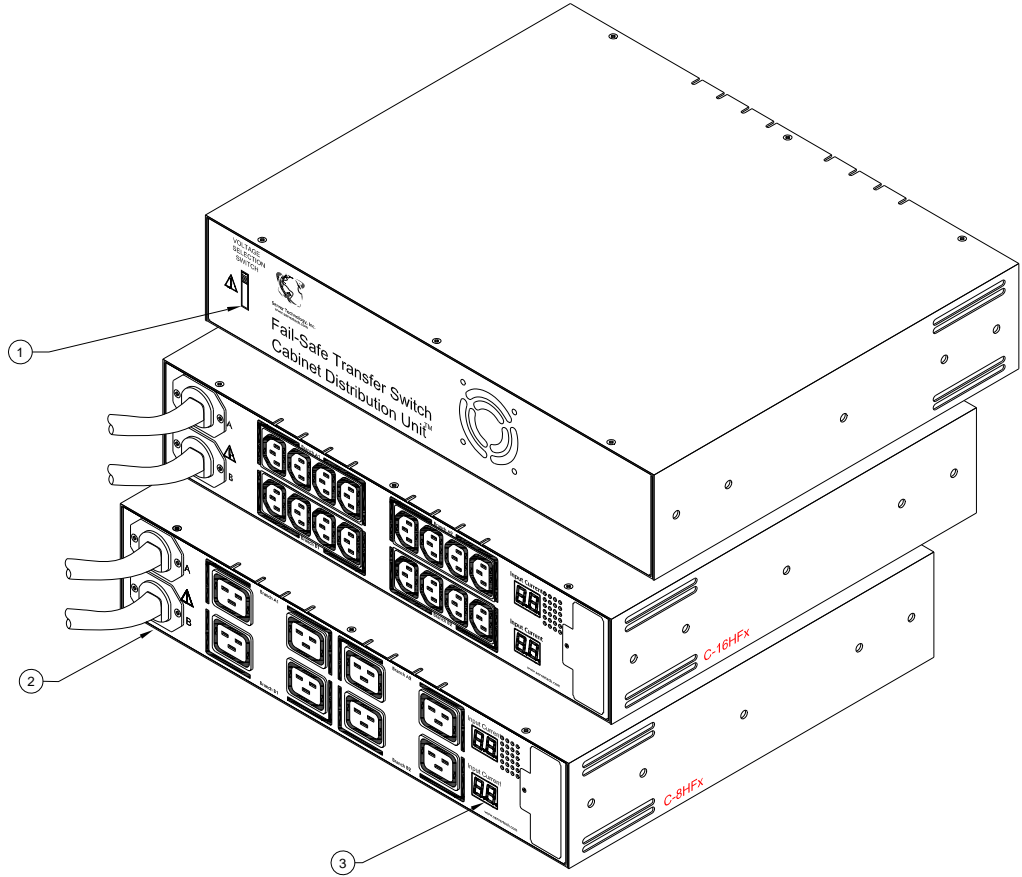

Figure 1. Sentry Rack-Mount Fail-Safe Transfer Switch Views

## Chapter 2: Installation

Before installing your Rack-Mount Fail-Safe Transfer Switch, refer to the following lists to ensure that you have all the items shipped with the unit as well as all other items required for proper installation.

### Standard Accessories

- Mounting hardware: Two removable flanges with M4 screws.
- Outlet retention clips (208-240V models).

Additional items for Cx-xxx-C20 models:

- Separate power input cords.
- Power input retention bracket hardware (may be installed):  
Four removable T-brackets with four 40mm screws.

### Additional Required Items

- Flathead and Phillips screwdrivers
- Screws, washers and nuts to attach the CDU to your rack

### Safety Precautions

This section contains important safety and regulatory information that should be reviewed before installing and using the Sentry Rack-Mount Fail-Safe Transfer Switch. For input and output current ratings, see *Power Ratings* in Appendix A: Technical Specifications.

Only for installation and use in a Service Access Location in accordance with the following installation and use instructions.

*Destiné à l'installation et l'utilisation dans le cadre de Service Access Location selon les instructions d'installation et d'utilisation.*

Nur für Installation und Gebrauch an Anschlusszugriffspunkten gemäß der folgenden Installations- und Gebrauchsanweisungen.

This equipment is designed to be installed on a dedicated circuit.

*Cet équipement est conçu à être installé sur un circuit spécialisé.*

Diese Ausrüstung ist zur Installation in einem festen Stromkreis vorgesehen.



Dedicated circuit must have circuit breaker or fuse protection. CDUs have been designed without a master circuit breaker or fuse to avoid becoming a single point of failure. It is the customer's responsibility to provide adequate protection for the dedicated power circuit. Protection of capacity equal to the current rating of the CDU must be provided and must meet all applicable codes and regulations. In North American, protection must have a 10,000A interrupt capacity.

*Le circuit spécialisé doit avoir un disjoncteur ou une protection de fusible. CDUs ont été conçus sans disjoncteur général ni fusible pour éviter que cela devienne un seul endroit de panne. C'est la responsabilité du client de fournir une protection adéquate pour le circuit-alimentation spécialisé. Protection de capacité équivalente à la puissance de l'équipement, et respectant tous les codes et normes applicables. Les disjoncteurs ou fusibles destinés à l'installation en Amérique du Nord doivent avoir une capacité d'interruption de 10.000 A.*

Der feste Stromkreis muss mit einem Schutzschalter oder einem Sicherungsschutz versehen sein. CDUs verfügt über keinen Hauptschutzschalter bzw. über keine Sicherung, damit kein einzelner Fehlerpunkt entstehen kann. Der Kunde ist dafür verantwortlich, den Stromkreis sachgemäß zu schützen. Der Kapazitätsschutz entspricht der aktuellen Stromstärke der Geräte und muss alle relevanten Codes und Bestimmungen erfüllen. Für Installation in Nordamerika müssen Ausschalter bzw. Sicherung über 10.000 A Unterbrechungskapazität verfügen.

The plug on the power supply cord shall be installed near the equipment and shall be easily accessible.

*La prise sur le cordon d'alimentation sera installée près de l'équipement et sera facilement disponible.*

Der Stecker des Netzkabels muss in der Nähe der Ausrüstung installiert werden und leicht zugänglich sein.



Always disconnect the power supply cords before opening to avoid electrical shock.

*Toujours déconnecter le cordon d'alimentation avant d'ouvrir pour éviter un choc électrique.*

Ziehen Sie vor dem Öffnen immer das Netzkabel heraus, um die Gefahr eines elektrischen Schlags zu vermeiden.



WARNING! High leakage current! Earth connection is essential before connecting supply!

*ATTENTION! Haut fuite très possible! Une connexion de masse est essentielle avant de connecter l'alimentation!*

ACHTUNG! Hoher Ableitstrom! Ein Erdungsanschluss ist vor dem Einschalten der Stromzufuhr erforderlich!



WARNING! Cx-xxE-x units Double Pole/Neutral Fusing

*ATTENTION! Les unités Cx-xxE-x Double Pôle/Fusible sur le Neutre*

ACHTUNG!: Cx-xxE-x Zweipolige bzw. Neutralleiter-Sicherung

## Installing the Power Input Retention Bracket

For units with a total maximum output <math><30\text{A}</math>, it may be necessary to install the power input retention bracket prior to mounting the unit within the rack.

### To install the power input retention bracket:

1. Remove the two screws attaching the IEC 60320 C19 inlet to the enclosure.
2. Assemble and attach the retention bracket to the enclosure as shown.

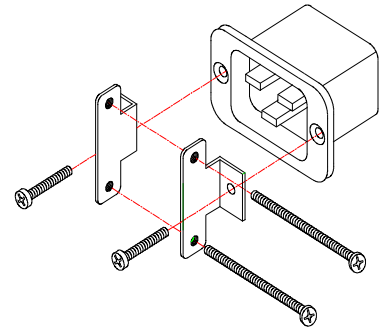

Figure 2.1 Retention Bracket assembly

## Mounting

1. Select the appropriate bracket mounting points for proper mounting depth within the rack.
2. Attach the brackets to these mounting points with two screws for each bracket.
3. Install the enclosure into your rack, using the slots in each bracket. The slots allow about  $\frac{1}{4}$  inch of horizontal adaptability to align with the mounting holes of your rack.

**NOTE:** A mounting bracket kit for 23" wide racks or cabinets is available. Contact your Server Technology Sales Representative for more information.

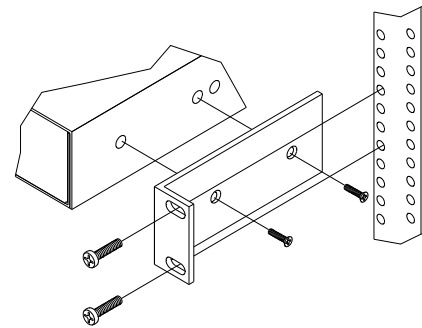

Figure 2. Mounting

## Optimizing the Transfer Thresholds

The Voltage Selector switch is used to optimize the transfer threshold by configuring the Transfer Switch for the nominal operational voltage of the installation. The Transfer Switch uses this setting to calculate the brownout and over-voltage threshold ( $\pm 13\%$ ).

### To optimize the transfer threshold:

Select the voltage setting that most closely matches the nominal operating voltage of the power sources.

## Connecting to the Power Source

### To attach a power cord to the unit:

1. Plug the female end of the power cord firmly into its connector at the base.
2. Use a screwdriver to tighten the two screws on the retention bracket.

### To connect to the power source:

Plug the male end of the power cord into the AC power source.

## Connecting Devices

1. Keep the device's on/off switch in the off position until after it is plugged into the outlet.
2. Connect devices to the CDU outlets.

**NOTE:** Server Technology recommends even distribution of attached devices across all available outlets to avoid exceeding the outlet, branch or phase limitations. See *Power Ratings* on page 9 for more information.



Always disconnect ALL power supply cords before opening to avoid electrical shock.  
Afin d'éviter les chocs électriques, débranchez TOUTES les câbles électrique avant d'ouvrir.  
Immer ALLE Netzleitungen auskuppeln vor den Aufmachen um elektrischen Schlag zu vermeiden.

# Chapter 3: Operations

## Modes of Operation

The Sentry Rack-Mount Fail-Safe Transfer Switch is designed to operate in the following modes:

- **Normal**  
Infeed A provides power to branches A1 & A2 and Infeed B provides power to branches B1 & B2. Each infeed is monitored individually for voltage and current.
- **Input Failure**  
The equipment powered by the failed input is transferred to the remaining input. The input current LED display of the failed input will be blank and the remaining display will report the total current load for the unit.
- **Recovery from Input Failure**  
When voltage is restored to the failed input and remains within  $\pm 7\%$  of nominal for 2 seconds, the equipment normally supported by that input is transferred back returning the Sentry to a 'Normal' mode with the input current LED displays reporting the total current load for each respective infeed.
- **Brownout/Over-Voltage**  
When an input's voltage varies from its nominal by  $\pm 13\%$  or more, the equipment powered by that input is transferred to the remaining input. The input current LED display of the input in the brownout/over-voltage state will be blank and the remaining display will report the total current load for the unit.

Nominal Voltage*	Brownout	Recovery Voltage		Over-Voltage
100V	87.0V	93.0V	107.0V	113.0V
110V	95.7V	102.3V	117.7V	124.3V
115V	100.0V	106.9V	123.0V	129.9V
120V	104.4V	111.6V	128.4V	135.6V
208V	181.0V	193.4V	222.6V	235.0V
220V	191.4V	204.6V	235.4V	248.6V
230V	200.1V	213.9V	246.1V	259.9V
240V	208.8V	223.2V	256.8V	271.2V

\*Nominal operating voltage is configured by the Voltage Selector Switch.

- **Recovery from Brownout/Over-Voltage**  
When the input's voltage returns to and remains within  $\pm 7\%$  of nominal for 2 seconds, the equipment normally supported by that input is transferred back returning the Sentry to a 'Normal' mode input current LED displays reporting the total current load for each respective infeed.
- **Critical Brownout**  
A critical brownout is when an input's voltage drops below its nominal by -25%.
  - When an input is already in a brownout/over-voltage state AND the remaining input experiences a critical brownout, ALL equipment will be transferred to the input only experiencing a brownout/over-voltage.
  - When an input has already failed AND the remaining input experiences a critical brownout, ALL outlets will turn off.
- **Recovery from Critical Brownout**  
When the input's voltage returns to and remains within  $\pm 7\%$  of nominal for 2 seconds, the equipment normally supported by that input is transferred back.

# Chapter 4: Appendices

## Appendix A: Technical Specifications

### Domestic Models

Model	Rated Voltage	Input Cordset and Plug (10')	Outlets
C-8HF2-C203	208-240V, 60Hz	IEC 60320 C20 <sup>1</sup>	8 IEC 60320/C19
C-8HF2-L303	208-240V, 60Hz	2 x NEMA L6-30P, 30A/208V Locking	8 IEC 60320/C19
C-16HF1-C20	100-120V, 60Hz	IEC 60320 C20 <sup>1</sup>	16 NEMA 5-20R
C-16HF1-L30	100-120V, 60Hz	2 x NEMA L5-30P, 30A/120V Locking	16 NEMA 5-20R
C-16HF2-C20	208-240V, 60Hz	IEC 60320 C20 <sup>1</sup>	16 IEC 60320/C13
C-16HF2-L30	208-240V, 60Hz	2 x NEMA L6-30P, 30A/208V Locking	16 IEC 60320/C13

### International Models

Model	Rated Voltage	Input Cordset and Plug (10')	Outlets
C-8HFE-C203	230V, 50Hz	IEC 60320 C20 <sup>1</sup>	8 IEC 60320/C19
C-8HFE-P323	230V, 50Hz	2 x IEC 60309, 32A 3-pin 6Hr Blue	8 IEC 60320/C19
C-16HFE-C20	230V, 50Hz	IEC 60320 C20 <sup>1</sup>	16 IEC 60320/C13
C-16HFE-P32	230V, 50Hz	2 x IEC 60309, 32A 3-pin 6Hr Blue	16 IEC 60320/C13

<sup>1</sup> Input cordset selected at time of purchase

### Power Ratings

Model Modele Modell	Input Current Ratings <i>L'indice du courant d'entrée</i> Eingangsstromstärke		Output Current Ratings <i>L'indice du courant de sortie</i> Ausgangsstromstärke			Total Total Insgesamt
	Voltage <i>Tension</i> Spannung	Current <i>Courant</i> Strom	Voltage <i>Tension</i> Spannung	Outlet <i>Prise</i> Anschlussstelle	Branch Circuit <i>Circuit de la Branche</i> Zweigstromkreis	
C-16HF1-C20	100-120V 60Hz	A: 16 B: 16	100-120V 60Hz	16	16	16
C-16HF1-L30	100-120V 60Hz	A: 24 B: 24	100-120V 60Hz	16	16	24
C-8HF2-C203	208-240V 60Hz	A: 16 B: 16	208-240V 60Hz	16	16	16
C-8HF2-L303	208-240V 60Hz	A: 24 B: 24	208-240V 60Hz	16	16	24
C-16HF2-C20	208-240V 60Hz	A: 16 B: 16	208-240V 60Hz	12	16	16
C-16HF2-L30	208-240V 60Hz	A: 24 B: 24	208-240V 60Hz	12	16	24
C-8HFE-C203	230V 50Hz	A: 16 B: 16	230V 50Hz	16	16	16
C-8HFE-P323	230V 50Hz	A: 32 B: 32	230V 50Hz	16	20	32
C-16HFE-C20	230V 50Hz	A: 16 B: 16	230V 50Hz	10	16	16
C-16HFE-P32	230V 50Hz	A: 32 B: 32	230V 50Hz	10	20	32

<sup>1</sup> All current ratings are in amperes. *Tous les indices de courant sont en ampères.* Alle Angaben der Stromstärke erfolgen in Ampere.

### Physical Specifications

	Operating	Storage
<b>Temperature</b>	32° to 104° F (0° to 40° C)	-40° to 185° F (-40° to 85° C)
<b>Elevation</b> (above MSL)	0 to 10,000 ft (0 to 3000m)	0 to 50,000 ft (0 to 15000m)
<b>Relative Humidity</b>	10 to 90%, non-condensing	10 to 90%, non-condensing
	Dimensions (H x W x D)	Weight
C-xHF	3.5 x 17.0 x 14.0 in. (90 x 437 x 356 mm)	20.7 lbs (9.4 kg)

### Transfer Rate

Power transfer ≤ 18 milliseconds.

## **Regulatory Compliance**

### **Product Safety**

Units have been safety tested and certified to the following standards:

- USA/Canada UL 60950:2003 and CAN/CSA 22.2 No. 60950-1-03
- European Union EN60950-1:2001

This product is also designed for Norwegian IT power system with phase-to phase voltage 230V.

### **USA Notification**

Note: This equipment has been tested and found to comply with the limits for a Class A digital device, pursuant to part 15 of the FCC Rules. These limits are designed to provide reasonable protection against harmful interference when the equipment is operated in a commercial environment. This equipment generates, uses, and can radiate radio frequency energy and, if not installed and used in accordance with the instruction manual, may cause harmful interference to radio communications. Operation of this equipment in a residential area is likely to cause harmful interference in which case the user will be required to correct the interference at the user's own expense.

Modifications not expressly approved by the manufacturer could void the user's authority to operated the equipment under FCC rules.

### **Canadian Notification**

This Class A digital apparatus complies meets all requirements of the Canadian Interference-Causing Equipment Regulations.

Cet appareil numérique de la classe A respecte toutes les exigences du Règlement sur le matériel brouilleur du Canada.

### **European Union Notification**

Products with the CE Marking comply with both the EMC Directive (89/336/EEC) and the Low Voltage Directive (73/23/EEC) issued by the Commission of the European Community.

Compliance with these directives implies conformity to the following European Norms:

- EN55022 Electromagnetic Interference
- EN55024 Electromagnetic Immunity
- EN60950-1 Product Safety
- EN61000-3 Harmonics and Flicker



Products with the following mark comply with the RoHS Directive (2002/95/EC) issued by the Commission of the European Community.

### **Japanese Notification**

この装置は、情報処理装置等電波障害自主規制協議会（VCCI）の基準に基づくクラスA情報技術装置です。この装置を家庭環境で使用すると電波妨害を引き起こすことがあります。この場合には使用者が適切な対策を講ずるよう要求されることがあります。

## **Recycling**



Server Technology Inc. encourages the recycling of its products. Disposal facilities, environmental conditions and regulations vary across local, state and country jurisdictions, so Server Technology encourages consultation with qualified professional and applicable regulations and authorities within your region to ensure proper disposal.

### **Waste Electrical and Electronic Equipment (WEEE)**



In the European Union, this label indicates that this product should not be disposed of with household waste. It should be deposited at an appropriate facility to enable recovery and recycling.

For information on how to recycle this product responsibly in your country, please visit:

[www.servertech.com/support/recycling](http://www.servertech.com/support/recycling).

## Appendix B: Warranty, Product Registration and Support

### Warranty

For [Server Technology Warranty](#) information, please see our website.

### Product Registration

Registration is your key to special offers and services reserved for Registered Users.

- Excellent Technical Support Services
- Special Update and Upgrade Programs
- Warranty Protection
- Extended Warranty Service
- New Product Information

[Register your products online today!](#)

### Technical Support



Experience Server Technology's FREE **SMARTER** Technical Support - [Learn more...](#)

Server Technology understands that there are often questions when installing and/or using a new product. Free Technical Support is provided from 6:00 AM to 7:00 PM, Monday-Friday, Pacific Time.

Server Technology, Inc.

1040 Sandhill Drive

Tel: 775.284.2000

Web: [www.servertech.com](http://www.servertech.com)

Reno, Nevada 89521 USA

Fax: 775.284.2065

Email: [support@servertech.com](mailto:support@servertech.com)

### Return Merchandise Authorization

If you have a unit that is not functioning properly and is in need of technical assistance or repair:

Please review Server Technology's [Return Merchandise Authorization](#) process on our website.



## Server Technology

### HEADQUARTERS – NORTH AMERICA

**Server Technology, Inc.**  
1040 Sandhill Drive  
Reno, NV 89521  
United States  
+1.775.284.2000 Tel  
+1.775.284.2065 Fax  
sales@servertech.com  
www.servertech.com  
www.servertechblog.com

### EMEA

**Server Technology Intl**  
Sienna Court  
The Broadway  
Maidenhead  
Berkshire  
SL6 1NJ  
United Kingdom  
+44 (0) 1628 509503 Tel  
+44 (0) 1628 509100 Fax  
salesintl@servertech.com

### APAC

**Server Technology, Inc.**  
Singapore  
+65 (0) 6829 7008 Tel  
+65 (0) 6234 4574 Fax  
salesintl@servertech.com