



Server Technology Inc.

Power Efficiency Gains by Deploying 415 VAC Power Distribution in North American Data Centers

White Paper STI-100-008
2011-Sept-22

Headquarters
Server Technology, Inc.
1040 Sandhill Drive
Reno, NV 89521
United States of America
+001 (775) 284 2000 Tel
+001 (775) 284 2065 Fax
sales@servertech.com
www.servertech.com
www.servertechblog.com

EMEA
Server Technology Intl.
Sienna Court
The Broadway
Maidenhead
Berkshire
SL6 1NJ
United Kingdom
+44 (0) 1628 509053 Tel
+44 (0) 1628 509100 Fax
salesintl@servertech.com

APAC
Server Technology, Inc.
37th Floor, Singapore Land
Tower
50 Raffles Place
Singapore, 048623
+65 (0) 6829 7008 Tel
+65 (0) 6234 4574 Fax
salesintl@servertech.com

Overview

Within enterprise data centers, power used for operating the facility, lighting, running IT loads and cooling it is the largest operational expense within the facility. Numerous papers and articles have been published by The Green Grid, The Uptime Institute, PG&E, Lawrence Berkeley Laboratories and others discussing ways to measure, monitor and increase efficiencies. This paper discusses various approaches to reducing power consumption and to increase end-to-end efficiency in the data center by bringing 415 VAC to the cabinet level. With power densities continuing to rise, more efficient solutions continue to be explored especially as power cost increases and power availability decreases.

The power path from the building entrance to the IT loads contains several power converters and transformers with each conversion; there is a loss of power. Reducing the number of transformers and operating at a higher voltage improves efficiency and reduces electrical costs. This paper discusses an alternative approach to power distribution, presently being implemented in North American data centers that increase efficiencies and savings by reducing upfront capital costs, power consumption and floor space.

Baseline: Current North American 208 VAC 3-phase Power Distribution

To understand this new approach to power distribution within the cabinet, it helps to understand the current standard distribution systems. In North America, 277/480 VAC, 3-phase power is delivered to most large commercial buildings and IT facilities. The voltages are measured from line-to-neutral (277 VAC) and line-to-line (480 VAC), as shown below in Figure 1. Automatic switching power supplies inside IT equipment typically operate within a range from 100 VAC to 240 VAC single-phase so the utility power delivered to the facility must be stepped down from 277 VAC through isolation transformers before it may be used, as outlined in Figure 3. This is achieved by routing the power through a Power Distribution Unit (PDU) transformer where it is stepped down from 480 VAC 3-phase to 208 VAC 3-phase.

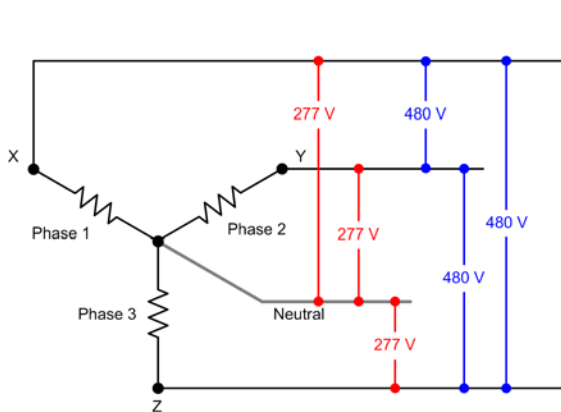

Figure 2. 480 VAC 3-phase power at the building entrance

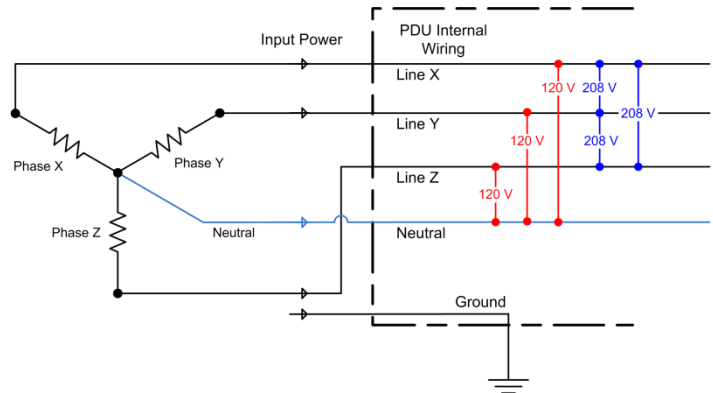

Figure 1. 208 VAC 3-phase after the PDU transformer. 120 VAC line-to-neutral

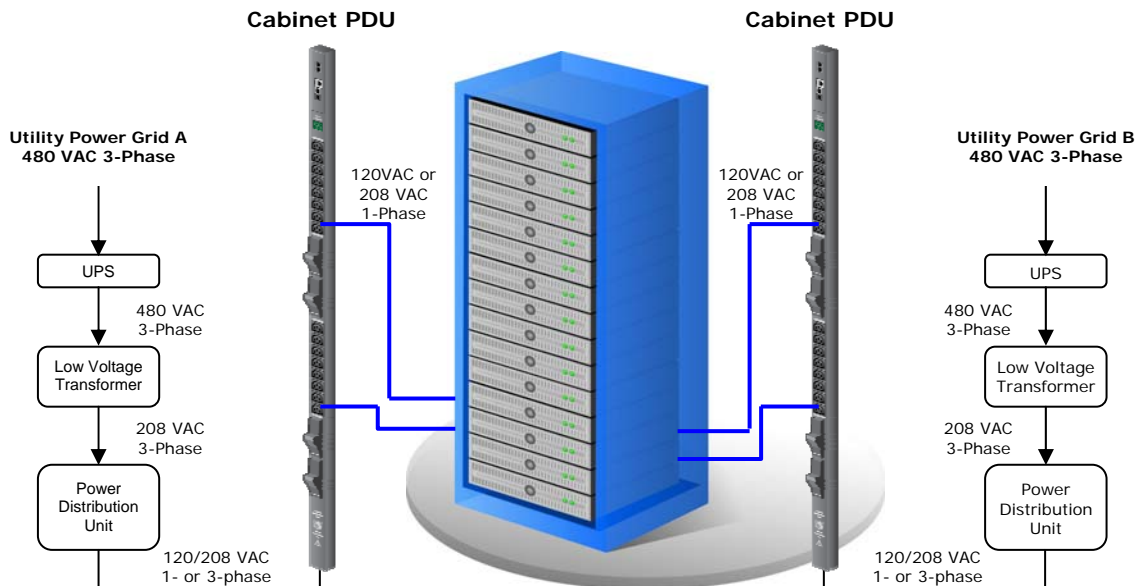

Figure 3. 480 VAC 3-phase to 208 VAC power path

From the primary PDU, power is typically distributed in three ways by remote power panels (RPP) or cabinet-level power distribution units (CDU):

1. 120 VAC single-phase (measured line-to-neutral)
2. 208 VAC single-phase (measured line-to-line)
3. 208 VAC 3-phase (in a Delta or Wye configuration).

Most IT devices have automatic switching power supplies that will accept both low-line voltages 100-120 VAC and high-line voltages 200-240 VAC. Running devices at the higher voltages will increase efficiencies approximately 2 to 3.5 percent, so the first step for data center managers is to ensure all devices that are capable of operating at 208 VAC are doing so by reviewing the nameplate ratings to determine the operating voltage range. In 208 VAC distribution systems, 208 VAC is achieved by powering IT devices with a line-to-line configuration versus line-to-neutral for 120 VAC, Figure 2. The advantage of this system is the capability of delivering 120 VAC for legacy devices; however, as mentioned before, most devices have universal power supplies capable of operating at higher voltages.

Within the IT device's internal power supply, power goes through one more transformation and conversion where 120 VAC or 208 VAC is rectified to DC and stepped down to 12 VDC or other voltages using DC-DC conversion circuitry, Figure 4.

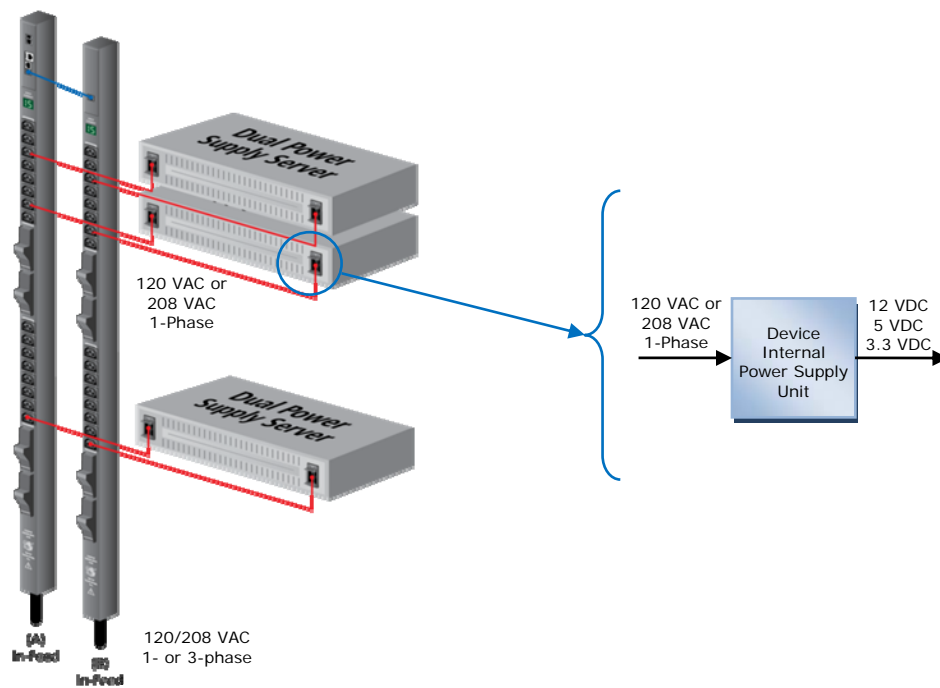

Cabinet Power Distribution Unit

Figure 4. CDU power distribution within the rack

With demands for higher densities and compute power, the 208 VAC 3-phase distribution system is being replaced with a 415 VAC 3-phase systems commonly used throughout the world.

415 VAC 3-phase Power Distribution

Power and cost savings in the data center can be achieved by reducing the number of power transformations and operating at higher voltages. This can be done by converting the UPS output from 277/480 VAC to 240/415 VAC through an autotransformer and eliminating the PDU transformer. Alternatively, the PDU transformer may be replaced with a PDU autotransformer. In a 415 VAC distribution system, the line-to-neutral voltage is 240 VAC. It is important to note that this is a significant difference from the typical US Baseline System where the line-to-neutral voltage is 120 VAC after the PDU transformer. This approach doubles the voltage being delivered to the devices while increasing efficiencies and reducing installation costs by eliminating components and using smaller diameter cables for distribution.

The 415 VAC power distribution system that is used in much of the world outside of North America is now beginning to gain a foothold within the U.S. and Canada. According to various UPS manufacturers, eliminating the PDU transformer will result in a 2% efficiency gain.

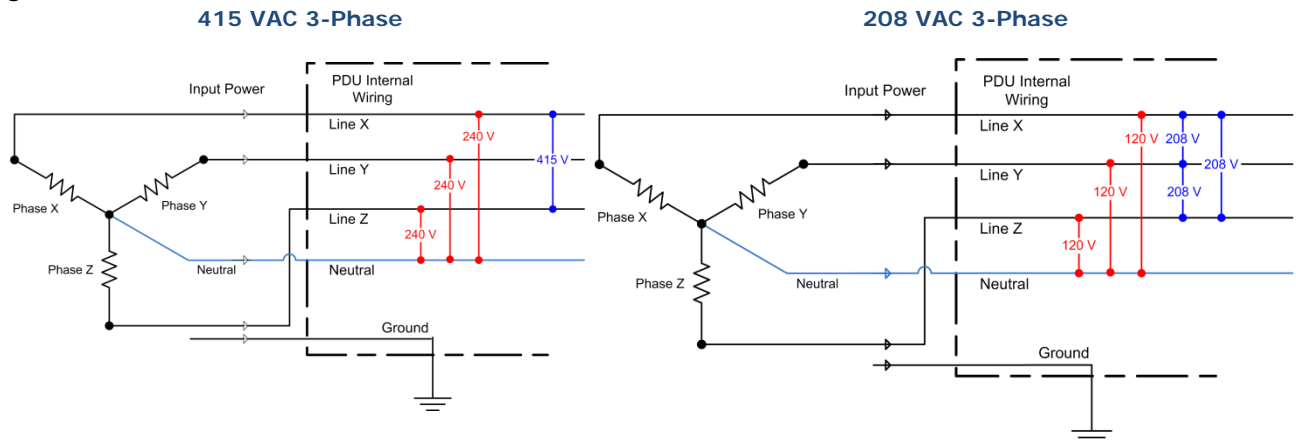

Figure 5. Difference between 415 VAC and 208 VAC power distribution systems

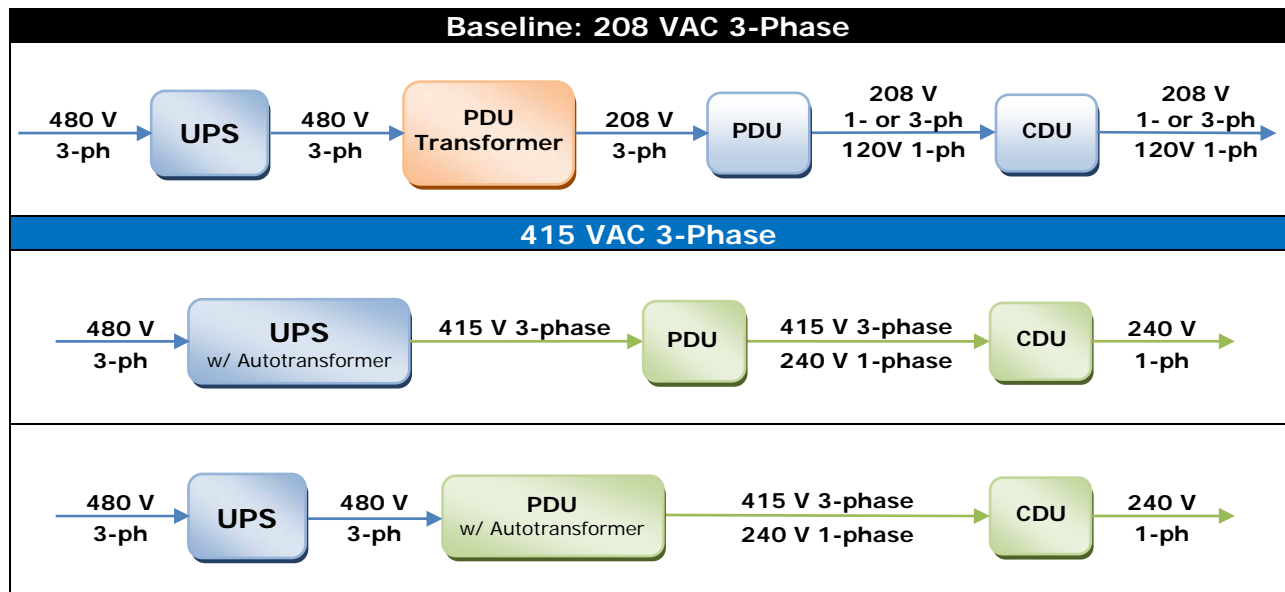

Figure 6. Comparison between the baseline power path and the 415 VAC power path with the elimination of the PDU transformer

Additionally, operating rack-level equipment at 240 VAC vs. 208 VAC will provide an additional 1% to 1.5% efficiency gain as shown in Table 1 for the HP ProLiant DL380.

Table 1. HP ProLiant DL380 Generation 5 (G5)

Power Supply Specification						
Operational Input Voltage Range (Vrms)	90 to 264					
Frequency Range (Nominal) (Hz)	47 to 63 (50/60)					
Nominal Input Voltage (Vrms)	100	120	208	220	230	240
Max Rated Output Wattage Rating	800	850	1000	1000	1000	1000
Nominal Input Current (A rms)	10.0	8.8	5.85	5.5	5.2	4.97
Max Rated Input Wattage Rating (Watts)	980	1035	1193	1186	1172	1169
Max. Rated VA (Volt-Amp)	1000	1056	1217	1210	1196	1193
Efficiency (%)	81.5	82	84	84	85	85.5
Power Factor	0.98	0.98	0.98	0.98	0.98	0.98
Leakage Current (mA)	0.44	0.52	0.91	0.96	1.00	1.04
Max. Inrush Current (A peak)	30	30	30	30	30	30
Max. Inrush Current duration (mS)	3	3	3	3	3	3

To gain a better understanding of the benefits of a 415 VAC system, consider what is necessary to deliver redundant power to a high density rack of blade servers. Using the power configuration calculator from a major blade system manufacturer, the power requirement for four fully populated blade systems is 15.1 kW. Table 2 below shows four different approaches to delivering this amount of power to the rack along with the number of power drops needed to provide redundancy.

Table 2. Power Capacity Comparison

Voltage	1- or 3-Phase	Current	kW (Continuous Rating)	Power Drops Required	Total Drops for Redundancy	
415	3	30	21.6	17.3	1	2
208	1	30	6.2	5.0	4	8
208	3	30	10.8	8.6	2	4
208	3	60	21.6	17.3	1	2

415 VAC System

30 A x 3 x 240 V x 0.80 de-rating = 17.3 kW

208 VAC 1-Phase, 30 A System

30A x 208 V x 0.80 de-rating = 5.0 kW

208 VAC 3-Phase, 30 A System

30 A x 1.732 x 208 V x 0.80 de-rating = 8.6 kW

208 VAC 3-Phase, 60 A System

60 A x 1.732 x 208 V x 0.80 de-rating = 17.3 kW

Efficiency gains by implementing a 415 VAC design are typically 4 to 5%, see Figure 7. Upfront cost savings are also realized from eliminating the PDU transformer, using smaller gauge power cords and less expensive plugs, taking up fewer poles at the breaker panel and requiring fewer power drops to the cabinets. Additional savings come from reductions in cooling costs with the elimination of the PDU transformers and at the cabinet-level by having fewer CDUs and cable drops which can also impede airflow. Additionally, though a 208 V, 60 A system provides the same power as a 415 V, 30 A system, lower current flow allows use of smaller conductors thus lowering the initial costs and reduces line losses due to cable resistance.

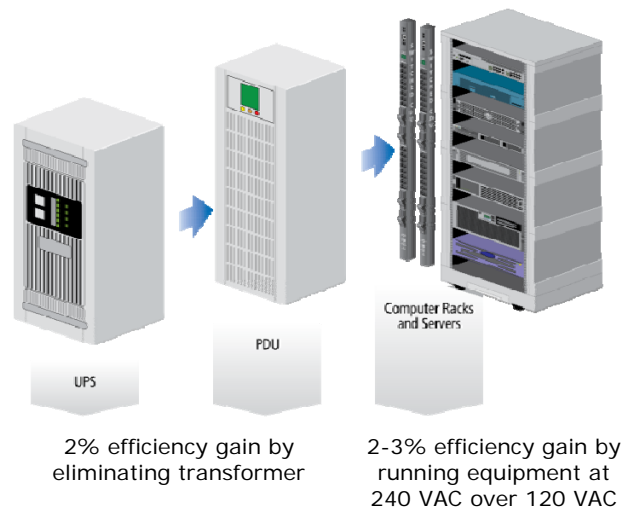

Figure 7. Efficiency gains by eliminating the transformer and running equipment at 240 V rather than 120 V

Table 3 demonstrates the annual cost savings by implementing a more efficient power distribution system based on a \$0.10 per kW-hr rate. Since energy rates vary from region to region, higher cost areas will realize greater savings. In general, power distribution equipment is more efficient and runs cooler while operating in the middle of their designed range; therefore additional cost savings can be achieved by understanding the capacity requirements for meeting immediate needs with the ability to expand to accommodate future growth.

Table 3. Annual energy savings from efficiency gains

IT Load (kW)	1%	2%	3%	4%	5%
250	\$2,190	\$4,380	\$6,570	\$8,760	\$10,950
500	\$4,380	\$8,760	\$13,140	\$17,520	\$21,900
750	\$6,570	\$13,140	\$19,710	\$26,280	\$32,850
1,000	\$8,760	\$17,520	\$26,280	\$35,040	\$43,800
1,500	\$13,140	\$26,280	\$39,420	\$52,560	\$65,700
2,000	\$17,520	\$35,040	\$52,560	\$70,080	\$87,600

Calculations based on \$0.10/kW-hr

Distributing 415 VAC at the Cabinet Level

At the cabinet level, power to the IT loads is distributed through a Cabinet Power Distribution Unit (CDU). The CDUs designed for 208 VAC 3-phase systems are not compatible with 415 VAC systems because they are wired line-to-line. In order to deliver 240 VAC single-phase, the outlets must be wired line-to-neutral. Server Technology offers designs that meet these requirements such as the Sentry Switched CDU below that offers a combination of IEC 60320 C13 and C19 outlets. Figure 8. Server Technology Cabinet Power Distribution Unit (CDU) shows an example of a CDU configured for 415 VAC service. This particular CDU has three outlet sections, each split into two branches protected by 20 A fuses allowing it to deliver 17.2 kW, the full capacity of the circuit. With this design, if the current in Branch 1 exceeds 20 A, it will blow the fuse and remove power to the branch leaving the rest of the CDU running normally.

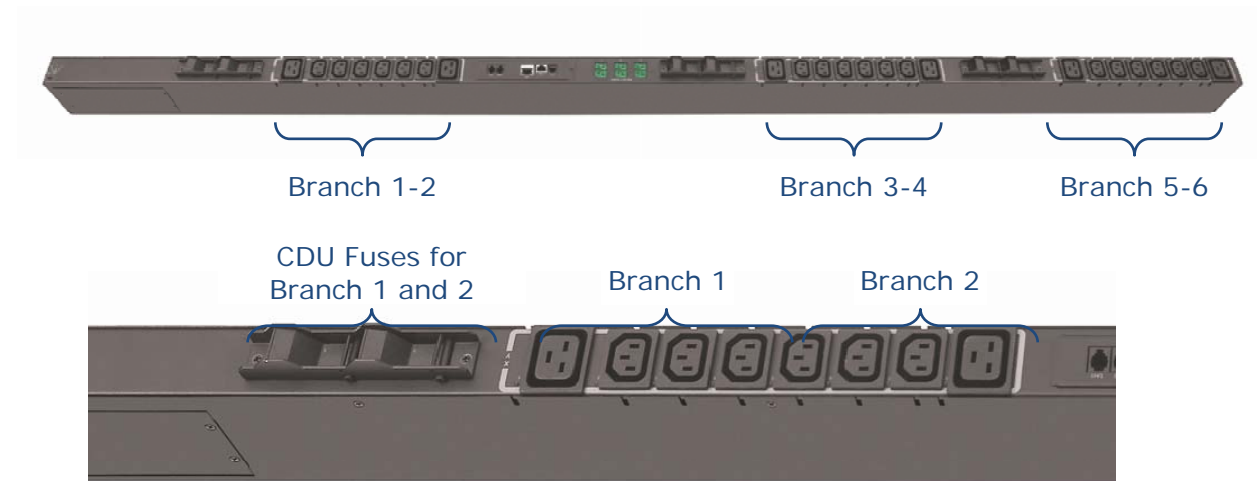

Figure 8. Server Technology Cabinet Power Distribution Unit (CDU)

Power Monitoring Using Server Technology POPS™ (Per Outlet Power Sensing)

In order to manage power usage, the capability to measure and monitor it must be present. Since the CDU is the most intelligent device closest to the IT load, it is an ideal point to monitor power consumption. Intelligent, Smart or Switched CDUs are equipped with local LEDs displays that provide useful information at the cabinet when powering up and load testing; however, they provide little useful information over the course of a day, week or month. Since power draw varies, CDUs designed with the ability to be networked and to allow power information to be queried, polled and trended at both a circuit and down to the device level will provide Data Center and Facilities managers a better understanding of actual equipment power usage and identify underutilized equipment.

Information can also be rolled up so power usage can be viewed by device, at an application level, or at a cabinet row or floor level. Additionally, the accumulated data may be used to calculate the PUE (Power Usage Effectiveness) and other metrics established by The Green Grid and other organizations to gauge and analyze power consumption and efficiency.

Environmental Monitoring

Maintaining the proper temperature and humidity range within the cabinet has become even more critical as densities within the cabinet and higher server utilization due to virtualization increases. Server Technology CDU's have the capability to monitor and send alerts from up to four combination temperature and humidity probe inputs. Additionally, when used with Server Technology's Sentry Power Manager, temperature, humidity and power may be logged and trended.

120 V IT Devices

IT equipment may be supplied with a 120 VAC NEMA power cord that will not be compatible with the CDU in a 415/240 VAC distribution system. Fortunately, most IT equipment manufacturers use power supplies that accept 100 V to 240 V and have standardized on IEC connectors for their products such as the Dell 2161 DS KVM Switch, which is designed with an IEC 60320 C14 inlet. This allows the power cord to be changed out to an IEC type cord. For those devices that do not have universal power supplies that will accept 240 VAC, rack-mounted transformers are available from a number of vendors.

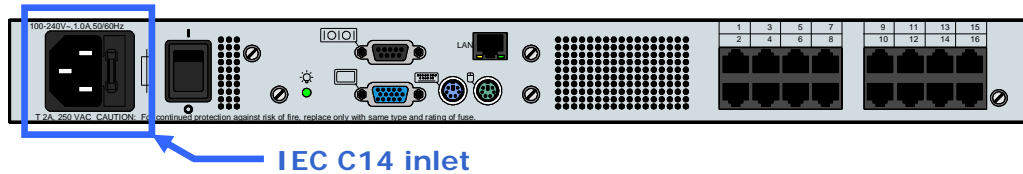

Figure 9. IT Equipment with IEC C14 inlet

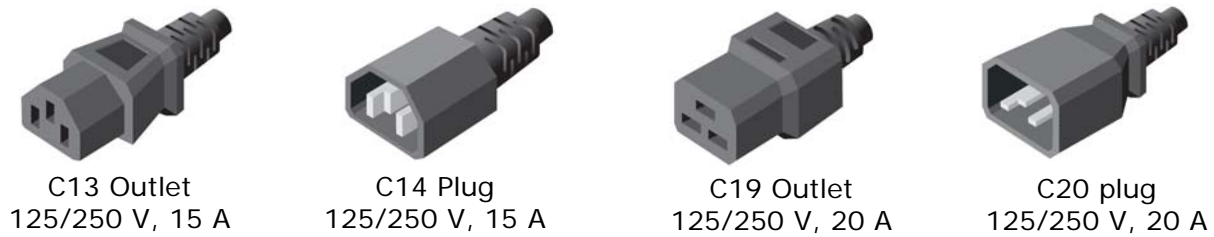

Figure 10. IEC 60320 outlets and plugs to connect IT equipment to the CDU

Summary

With small data centers operating in the range of tens of kW and large data centers running in tens of MW, incremental increases in efficiencies translate into large savings. There are several other proposed power distribution architectures being discussed such as rack-level and facilities-level DC power distribution and 277 VAC distribution. The Data Center Pulse group, an organization of data center owners, operators and users, recently held their inaugural conference in February 2009. They compiled a list of their top ten goals, one of which is to eliminate all transformers and deliver 277/480 VAC at the rack level. These discussions are beyond the scope of this paper; however, reducing the number of transformations and conversions will increase end-to-end efficiency. Server Technology understands these requirements and will continue to innovate and develop products to meet these needs.

Server Technology, the Server Technology Globe, CDU and Switched CDU are registered trademarks of Server Technology, Inc. All other trademarks and registered trademarks belong to their respective owners.